

CZT31C NPN
CZT32C PNP

**SURFACE MOUNT 2.0W
COMPLEMENTARY SILICON
POWER TRANSISTORS**

**POWER
223™**

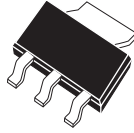

SOT-223 CASE

Central™
Semiconductor Corp.

DESCRIPTION:

The CENTRAL SEMICONDUCTOR CZT31C and CZT32C types are surface mount epoxy molded complementary silicon transistors manufactured by the epitaxial base process, designed for surface mounted power amplifier applications up to 3.0 amps.

MARKING CODE: FULL PART NUMBER

MAXIMUM RATINGS: ($T_A=25^\circ\text{C}$)

	SYMBOL		UNITS
Collector-Base Voltage	V_{CBO}	100	V
Collector-Emitter Voltage	V_{CEO}	100	V
Emitter-Base Voltage	V_{EBO}	5.0	V
Collector Current	I_C	3.0	A
Peak Collector Current	I_{CM}	6.0	A
Base Current	I_B	1.0	A
Power Dissipation	P_D	2.0	W
Power Dissipation ($T_C=25^\circ\text{C}$)	P_D	10	W
Operating and Storage Junction Temperature	T_J, T_{stg}	-65 to +150	$^\circ\text{C}$
Thermal Resistance	θ_{JA}	62.5	$^\circ\text{C/W}$
Thermal Resistance	θ_{JC}	12.5	$^\circ\text{C/W}$

ELECTRICAL CHARACTERISTICS: ($T_A=25^\circ\text{C}$ unless otherwise noted)

SYMBOL	TEST CONDITIONS	MIN	MAX	UNITS
I_{CES}	$V_{CE}=100\text{V}$		200	μA
I_{CEO}	$V_{CE}=60\text{V}$		300	μA
I_{EBO}	$V_{EB}=5.0\text{V}$		1.0	mA
BV_{CEO}	$I_C=30\text{mA}$	100		V
* $V_{CE(SAT)}$	$I_C=3.0\text{A}, I_B=375\text{mA}$		1.2	V
* $V_{BE(ON)}$	$V_{CE}=4.0\text{V}, I_C=3.0\text{A}$		1.8	V
* h_{FE}	$V_{CE}=4.0\text{V}, I_C=1.0\text{A}$	25		
* h_{FE}	$V_{CE}=4.0\text{V}, I_C=3.0\text{A}$	10	100	
f_T	$V_{CE}=10\text{V}, I_C=500\text{mA}, f=1.0\text{MHz}$	3.0		MHz

* Pulsed, 2%D.C.

R3 (17-June 2004)

SOT-223 CASE - MECHANICAL OUTLINE

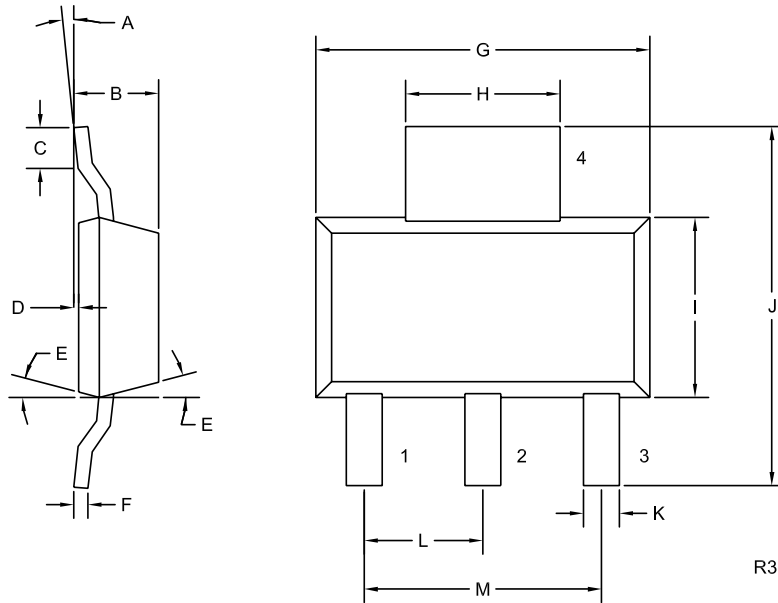

LEAD CODE:

- 1) BASE
- 2) COLLECTOR
- 3) EMITTER
- 4) COLLECTOR

MARKING CODE:

FULL PART NUMBER

SYMBOL	DIMENSIONS			
	INCHES		MILLIMETERS	
	MIN	MAX	MIN	MAX
A	0°	10°	0°	10°
B	0.059	0.071	1.50	1.80
C	0.018	---	0.45	---
D	0.000	0.004	0.00	0.10
E	15°		15°	
F	0.009	0.014	0.23	0.35
G	0.248	0.264	6.30	6.70
H	0.114	0.122	2.90	3.10
I	0.130	0.146	3.30	3.70
J	0.264	0.287	6.70	7.30
K	0.024	0.033	0.60	0.85
L	0.091		2.30	
M	0.181		4.60	

SOT-223 (REV: R3)

R3 (17-June 2004)